

Overview



MultiRanger 200 HMI is a versatile short to medium-range ultrasonic single and multi-vessel level monitor/controller for virtually any application in a wide range of industries.

Benefits

- Easy to use HMI display with local four-button programming, menu-driven parameters, and Wizard support for key applications
- English, German, French, Spanish, Chinese, Italian, Portuguese, and Russian texts on the HMI
- Removable terminal blocks for ease of wiring
- Digital input for back-up level override from point level device
- Communication using built-in Modbus RTU via RS 485 and SIMATIC PDM configuration software
- Compatible with SmartLinx system: PROFIBUS DP, PROFINET (cyclic access of process values only), DeviceNet, Modbus TCP/IP, and EtherNet/IP
- Single or dual point level monitoring
- Auto False-Echo Suppression for fixed obstruction avoidance
- Differential amplifier transceiver for common mode noise reduction and improved signal-to-noise ratio
- Level, volume, and flow measurements in open channels, differential control, extended pump control, and alarm functions
- Wall and panel mounting options

Application

MultiRanger 200 HMI can be used with various materials, including, water, municipal waste, acids, woodchips, or on materials with high angles of repose. MultiRanger 200 HMI offers true dual point monitoring, digital communications with built-in Modbus RTU via RS 485, as well as compatibility with SIMATIC PDM, allowing PC configuration and set-up. MultiRanger 200 HMI features Sonic Intelligence advanced echo-processing software for increased reading reliability.

MultiRanger 200 HMI will monitor open channel flow and features more advanced relay alarming and pump control functions as well as volume conversion.

It is compatible with chemical-resistant EchoMax transducers that are approved for hostile environments.

- Key Applications: wet wells, flumes/weirs, bar screen control, hoppers, chemical storage, liquid storage, crusher bins, dry solids storage

Design

The MultiRanger 200 HMI is available in wall or panel mounting options.

Level measurement

Continuous level measurement Controllers

MultiRanger 200 HMI

Technical specifications

| Mode of Operation | |
|---------------------------------|--|
| Measuring principle | Ultrasonic level measurement |
| Measuring range | 0.3 ... 15 m (1 ... 50 ft) |
| Measuring points | 1 or 2 |
| Input | |
| Analog | 0 ... 20 mA or 4 ... 20 mA, from alternate device, scalable |
| Discrete | 10 ... 50 V DC switching level Logical 0 ≤ 0.5 V DC Logical 1 = 10 ... 50 V DC max. 3 mA |
| Output | |
| EchoMax transducer | 44 kHz |
| Ultrasonic transducer | Compatible transducers: ST-H and EchoMax series XPS-10, XPS-15/15F, and XRS-5 |
| Relays | Rating 5 A at 250 V AC, non-inductive |
| mA output | 0 ... 20 mA or 4 ... 20 mA |
| • Max. load | 750 Ω, isolated |
| • Resolution | 0.1 % of range |
| Accuracy | |
| Error in measurement | <ul style="list-style-type: none"> • 0.25 % of range or 6 mm (0.24 inch), whichever is greater • ± 4 mm (0.16 inch) in combination with an XRS-5 transducer on ranges 4 m (13 ft) or less |
| Resolution | 0.1 % of measuring range ¹⁾ or 2 mm (0.08 inch), whichever is greater |
| Temperature compensation | <ul style="list-style-type: none"> • -50 ... +150 °C (-58 ... +302 °F) • Integral temperature sensor • External TS-3 temperature sensor (optional) • Programmable fixed temperature values |
| Rated operating conditions | |
| Installation conditions | Indoor/outdoor |
| • Location | II |
| • Installation category | 4 |
| • Pollution degree | |
| Ambient conditions | |
| • Ambient temperature (housing) | -20 ... +50 °C (-4 ... +122 °F) |
| • Storage temperature | -20 ... +50 °C (-4 ... +122 °F) |

| Mode of Operation | |
|--|---|
| Design | |
| Weight | |
| • Wall mount | 1.22 kg (2.68 lb) |
| • Panel mount | 1.35 kg (2.97 lb) |
| Material (enclosure) | Polycarbonate |
| Degree of protection (enclosure) | |
| • Wall mount | IP65/Type 4X/NEMA 4X |
| • Panel mount | IP54/Type 3/NEMA 3 |
| Electrical connection | |
| • Transducer and mA output signal | 2-core copper conductor, twisted, shielded, 0.5 ... 0.75 mm ² (22 ... 18 AWG), Belden 8760 or equivalent is acceptable |
| • Max. separation between transducer and transceiver | 365 m (1 200 ft) |
| Displays and controls | |
| | 60 x 40 mm (2.36 x 1.57 inch) LCD 240 x 160 pixels resolution |
| Power supply | |
| AC version | 100 ... 230 V AC ± 15 %, 50/60 Hz, 36 VA (17 W) |
| DC version | 12 ... 30 V DC (20 W) |
| Certificates and approvals | |
| | <ul style="list-style-type: none"> • CE, RCM, EAC, KCC²⁾ • FM, CSA_{US/C}, UL • CSA Class I, Div. 2, Groups A, B, C, and D, Class II, Div. 2, Groups F and G, Class III (wall mount only) |
| Communication | |
| | <ul style="list-style-type: none"> • RS 232 with Modbus RTU or ASCII via RJ-11 connector • RS 485 with Modbus RTU or ASCII via terminal strips • Optional: SmartLinX cards for <ul style="list-style-type: none"> - PROFIBUS DP-V1, PROFINET (cyclic access of process values only) - DeviceNet, Modbus TCP/IP, EtherNet/IP |

¹⁾ Program range is defined as the empty distance to the face of the transducer plus any range extension

²⁾ EMC performance available on request

| Selection and ordering data | Article No. | Order code |
|---|---------------------------------|------------|
| MultiRanger 200 Ultrasonic level controller Continuous, non-contact, 15 m (50 ft) range. Monitors level, volume, and open channel flow in liquids, slurries, and solids. Click on the Article No. for the online configuration in the PIA Life Cycle Portal. | 7ML5033- | |
| Versions MultiRanger 200, level, volume, flow, and differential measurements | 2 | |
| Mounting, enclosure design 4 button HMI, Wall mount, standard enclosure 4 button HMI, Wall mount, 4 entries, 4 M20 cable glands included 4 button HMI, Panel Mount | D E F | |
| Input voltage 100 ... 230 V AC 12 ... 30 V DC | A B | |
| Number of measurement points Single point version Dual point version | 0 1 | |
| Data communications (SmartLinx) Without module SmartLinx PROFIBUS DP V0 module SmartLinx DeviceNet module SmartLinx PROFIBUS DP V1 module SmartLinx PROFINET module ²⁾ SmartLinx EtherNet/IP module SmartLinx Modbus TCP/IP module See SmartLinx product page 4/348 for more information. | 0 2 3 4 5 6 7 | |
| Output relays 6 relays (4 Form A, 2 Form C), 250 V AC | 2 | |
| Approvals General Purpose CE, FM, CSA _{US/C} , UL listed, RCM, EAC, KCC CSA Class I, Div. 2, Groups A, B, C, and D; Class II, Div. 2, Groups F and G; Class III ¹⁾ | A B | |
| Further designs Please add "-Z" to Article No. and specify Order code(s). Stainless steel tag [69 x 50 mm (2.71 x 1.97 inch)]: Measuring-point number/identification (max. 27 characters) specify in plain text Y15 Test Certificate: Manufacturer's test certificate M to DIN 55350, Part 18 and to ISO 9000 C11 Operating Instructions All literature is available to download for free, in a range of languages, at http://www.siemens.com/processinstrumentation/documentation Optional equipment Tag, stainless steel, 12 x 45 mm, one text line, suitable for enclosures 7ML1930-1AC Sunshield, 304 Stainless steel 7ML1930-1GA SITRANS RD100, loop powered display - see Chapter 7 7ML5741-... SITRANS RD150, remote digital display for 4 ... 20 mA and HART devices - see Chapter 7 7ML5742-.....-.... SITRANS RD200, universal input display with Modbus conversion - see Chapter 7 7ML5740-... SITRANS RD300, dual line display with totalizer and linearization curve and Modbus conversion - see Chapter 7 7ML5744-... Spare parts Power Supply Board (100 ... 230 V AC) 7ML1830-1MD Power Supply Board (12 ... 30 V DC) 7ML1830-1ME Removable terminal blocks A5E38824197 Spare lid with HMI, MultiRanger 200 HMI/HydroRanger 200 HMI, wall A5E35778738 Spare lid with HMI, MultiRanger 200 HMI/HydroRanger 200 HMI, panel A5E35778740 SmartLinx DeviceNet module 7ML1830-1HT SmartLinx PROFIBUS DP V1 module A5E35778741 SmartLinx PROFINET IO module 7ML1830-1PM SmartLinx Modbus TCP/IP, EtherNet/IP module 7ML1830-1PN | | |

1) Available with Mounting/Enclosure design options D or E.

2) SmartLinx PROFINET module is certified per standard V2.2.4.

Level measurement

Continuous level measurement
Controllers

MultiRanger 200 HMI

Dimensional drawings

Panel mount dimensions

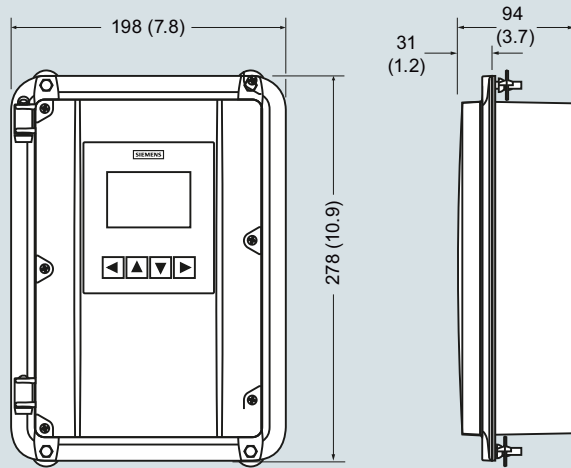

Wall mount dimensions

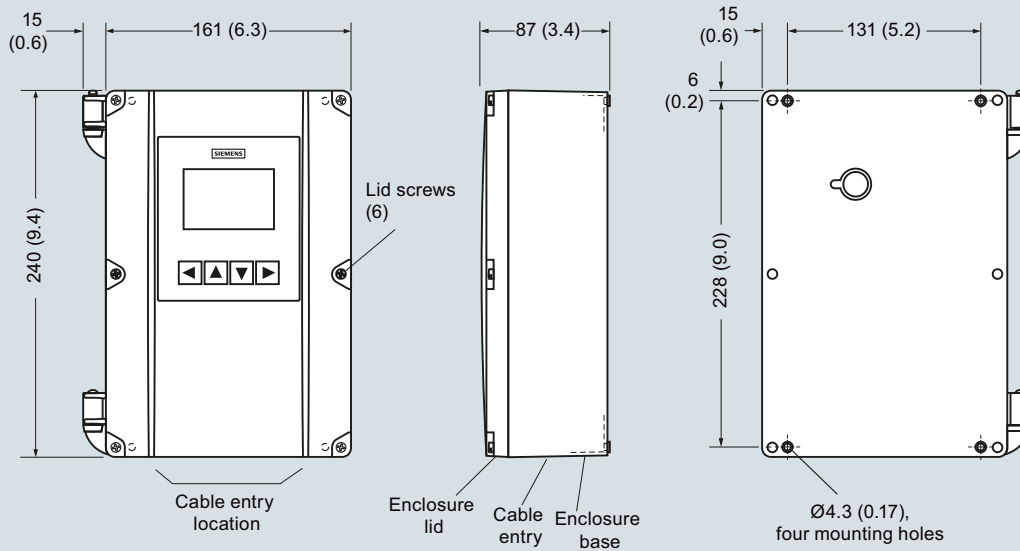

MultiRanger 200 HMI, dimensions in mm (inch)

Circuit diagrams

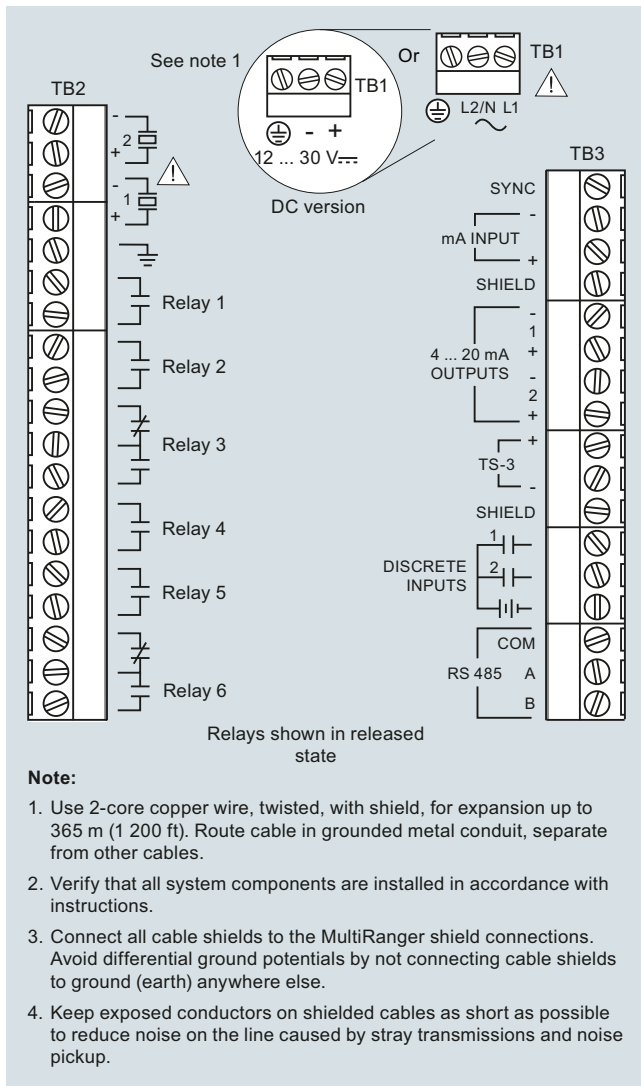

MultiRanger 200 HMI connections